

COMPLI 300 E

SEWAGE LIFTING STATIONS



- Ready to connect
- Submersible
- Auxiliary inlets vertical/horizontal
- Mounted swing-type check valve
- Light weight
- Less required space
- PE-tank
- Vortex impeller
- Smart home compatible

DESCRIPTION

The Compli 300 E is the smallest sewage lifting station of our Compli series. It has been designed for the disposal of sewage from housing units like basement dwellings. The Compli 300 E is all-purposed, due to compact dimensions of its tank and numerous connection facilities.

The low weight and the plug with integrated control board ensures a facile installation, so that an electrician is not needed to start running the unit.

The submersible unit permits a general application in rooms which could be flooded.

The connector housing with integrated control unit must be installed in rooms which are well ventilated and cannot be flooded.

The powerful alternating current motor of the Compli 300 is based on a rugged grey cast iron volute housing vat which grant a special stability and quiet running.

The Compli sewage lifting station can be integrated into a smart infrastructure. The FTJP radio transmitter is connected to the potential-free contact of the lifting station. It is now possible to transmit the switching status (e.g. an alarm message) to an EnOcean-capable smart home gateway (Wibutler, Afriso, Homee).

PERFORMANCE

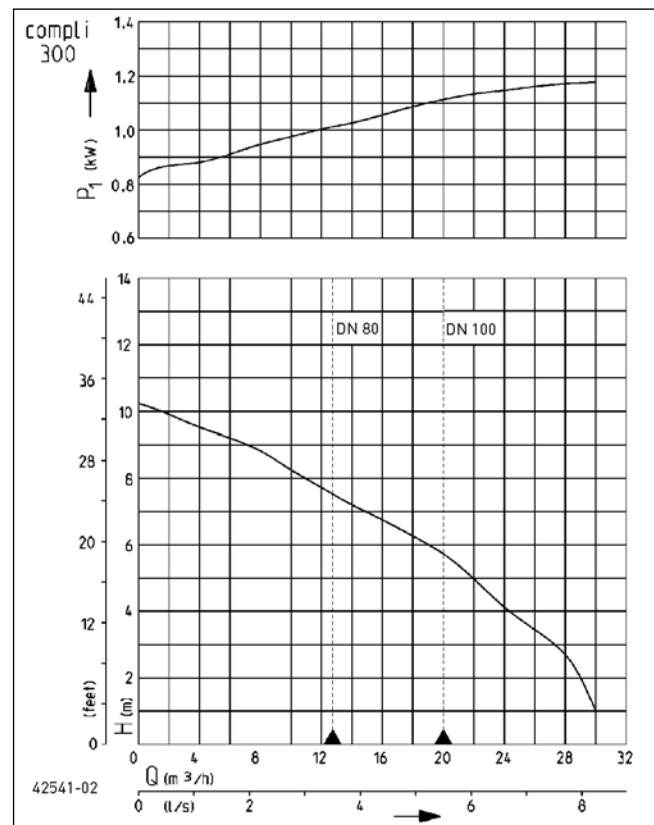

Type	Delivery head H [m]	1	2	3	4	5	6	7
compl i 300 E	Flow rate Q [m ³ /h]	30	29	28	24	22	19	15

Specifications can be changed without notice. Performance subject to ISO 9906 tolerances. The minimum flow velocity in the pressure piping must be 0.7 m/s according to EN 12056. This data is represented in the performance curve as a limit of application.



COMPLI 300 E

SEWAGE LIFTING STATIONS



SCOPE OF SUPPLY

Ready to connect sewage disposal unit acc. to EN 12050-1 with clamp flange DN 100 for inlet height 180 mm, additional inlets DN 100/50 horizontal and vertical, submersible pump and flange DN 80 with piece of pipe \varnothing 90 mm, with integrated swing-type check valve DN 80, one elastic connection hose band clamps for plastic

pipe DN 80 and for pressure pipe DN 70, autom. level control, control unit (type of enclosure IP 44) with mains-dependent alarm buzzer, stand-by LED, hand-0-automatic selector switch and potential free NO contact for an additional alarm. Cable 4 m.

MECHANICAL DATA

Pump	Vertical single-stage	Pump housing	Grey cast iron
Free passage	50 mm	Submersible	Yes
Pressure pipe	DN 80	Pressure outlet	DN 80
Shaft	Stainless steel	Tank capacity	50 l
Impeller	Vortex impeller, GFK	Weight	31 kg
Motor housing	Stainless steel		

ELECTRICAL DATA

Voltage	1/N/PE~230 V	Wires	4G0,75
Motor rating P1	1.37 kW	Type of enclosure	IP 68
Motor rating P2	0.98 kW	Insulation class	B
Current	6 A	Winding thermostat	Yes
Power line	4m H07RN-F	Plug	Safety

COMPLI 300 E

Type	Code No.
compli 300 E	JP50076

COMPLI 300 E

SEWAGE LIFTING STATIONS



Dimensions with swing-type check valve (mm)

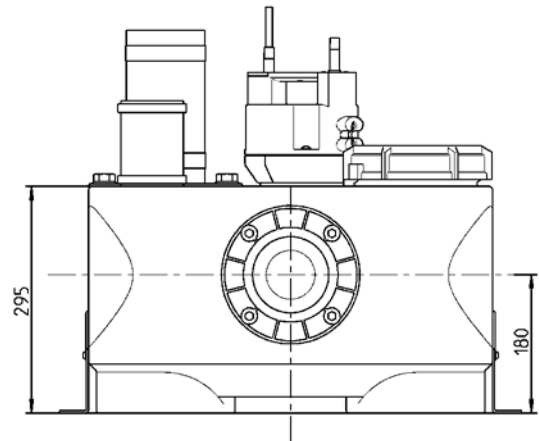
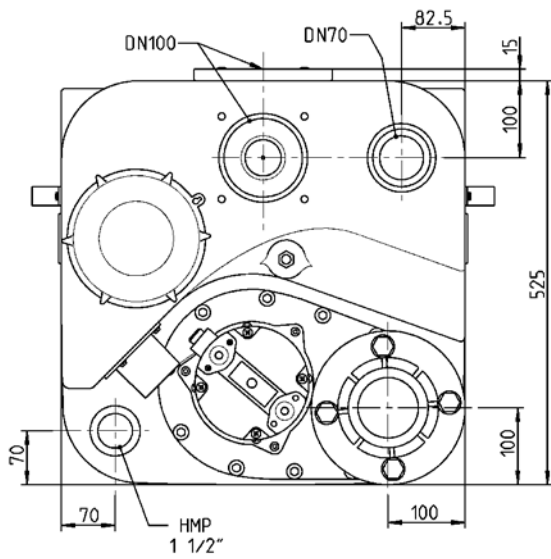
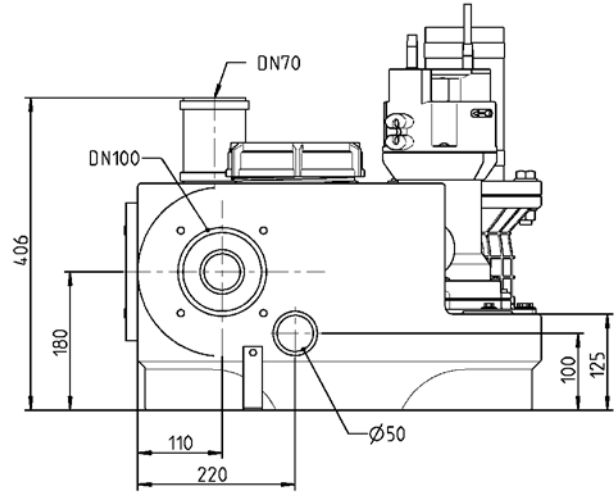
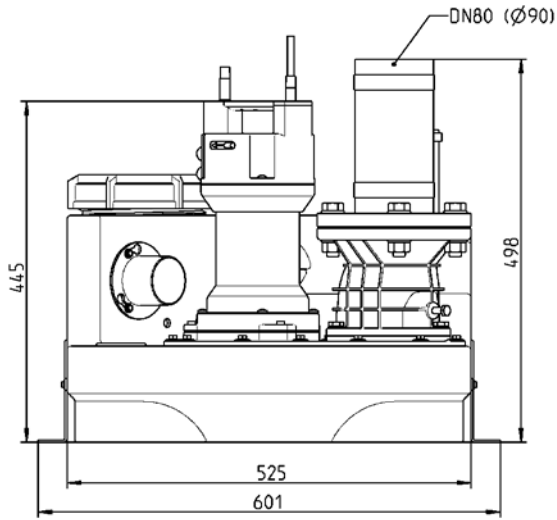

42205-05

Example of installation

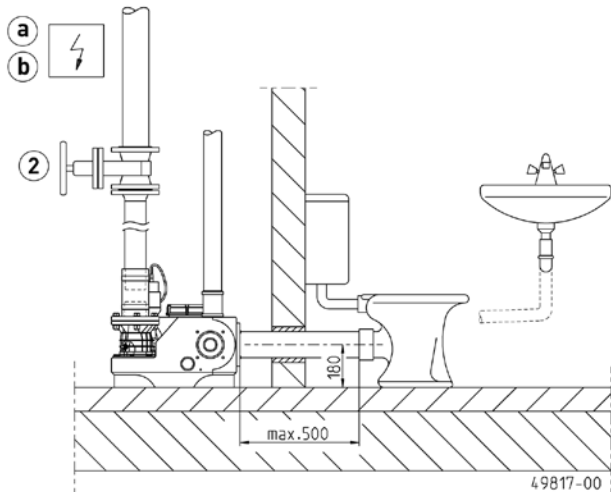

Example of installaton

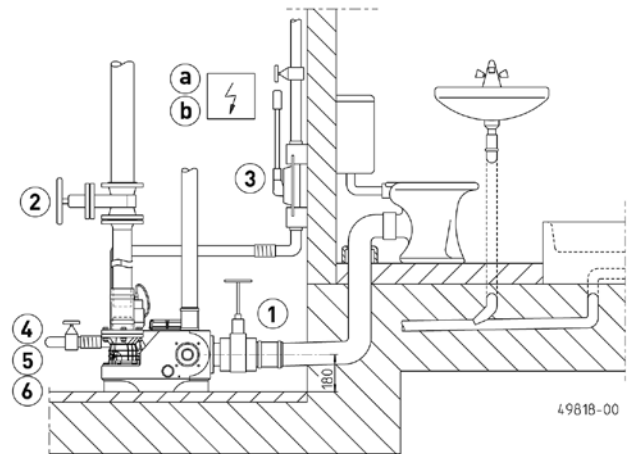







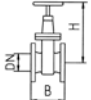

The Compli has a DN 80/PN 4 outlet flange. The following stop valve and pipework are installed in DN 80.
 In keeping with the construction and testing principles of European standard EN 12050, sewage lifting stations are to be used for the transport of faecal matter and domestic wastewater in building drainage systems as described in German standard DIN 1986 T3. In keeping with the stipulations of European standard EN 12056-4 they have to be mounted with collecting tanks inside building permitting a free space of 60 cm for operation and

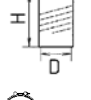

repair. The pressure pipe has to be passed above the locally defined backpressure level and a non-return valve tested in keeping with European standard 12050-4 has to be mounted. In keeping with European standard 12056 the ventilation pipe has to be passed up to the roof.

Attention! The inlet pipes of the lowlateral inlets must be equipped with a dam loop. This loop must have at least a height of 180 mm between ground and invert. The feed line must be ventilated on its highest elevation.

MECHANICAL ACCESSORY

				Code No.
	① Inlet gate valve PVC	with two pipe sockets, DN 100, PN1	360x295 (HxW)	JP28297
	② Sluice valve	DN 80, PN 10, EN 1171	315x180 (HxB)	JP00639
	③ Connection for emergency de-watering	with stop valve and hose connection 1", 1¼" and 1½"		JP49138
	Hand diaphragm pump	for emergency purposes (up to H geod 15 m)	640x1½" (HxD)	JP00255
	④ Stop valve	brass, 1½" (DN 40), PN 16	125x60 (HxB)	JP44786
	⑤ Elastic connection	1½" (DN 40), PN 4	120x50 (HxD)	JP44777
	⑥ Hose band clamp	1½"		JP44763
	⑦ Adapter ring	DN 80-DN 80 SML		JP50173
	⑧ Connection kit	DN 100	D=110	JP42910

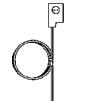
ELECTRICAL ACCESSORY

			Code No.
	① Alarm unit		
	AGR	reed switch, mains dependent, potential-free contact, 4 m cable	JP44893
	② Rechargeable battery	9 V, for mains independent alarm	JP44850